





ASSEMBLY INSTRUCTION/ INSTRUCTION D'ASSEMBLAGE

ITEM NO : B2048-BC4S : BOOKCASE WITH 4 SHELF/
BIBLIOTHÈQUE 4 ÉTAGÈRES

Thank you for purchasing this product. Please take time to read and follow the instructions below. Check that you have all parts and hardware before assembly. Parts apparently missing are often found in the packing materials. If you do not have all the parts listed, have your dealer contact us and they will be sent to you immediately.

Merci d'avoir acheté ce produit de qualité. Vérifiez avant le montage que vous avez toutes les pièces et fixations. Les pièces qui semblent manquer se trouvent souvent dans les matériaux d'emballage. Si vous n'avez pas toutes les pièces de la liste, demandez à votre détaillant et nous vous les enverrons immédiatement.





 It is recommended to install protective pads under all legs and supports to avoid damage or scratches when placing furniture on a wood floor or other hard surface, and to limit indentation and prevent discoloration if placing on carpet.

 Il est recommandé de placer des coussins protecteurs sous tous les pieds et toutes les bases des meubles pour éviter d'endommager ou d'égratigner les planchers en bois ou autres surfaces dures, et pour limiter l'empreinte et empêcher la décoloration quand les meubles reposent sur la moquette.

 Hardware may loosen over time. Periodically check to make sure all connections are tight. Re-tighten if necessary.

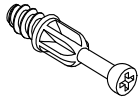
 Le matériel peut se desserrer au fil du temps. Vérifiez périodiquement que toutes les connexions sont serrées. Serrer à nouveau si nécessaire.

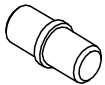
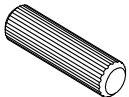
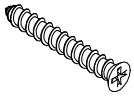
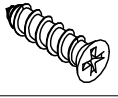
HARDWARE LIST / LISTE DE QUINCAILLERIE

NO	SKETCH / EQUISSER	DESCRIPTION / LA DESCRIPTION	SIZE / TAILLE	QTY / QTÉ
1		MINIFIX		12 PCS
2		HOUSING		12 PCS
3		SHELF PIN		8 PCS
4		WOODEN DOWEL	M8 x 30mm	8 PCS
5		CSK SCREW	M4 x 30mm	14 PCS
6		CSK SCREW	M3.5 X 16mm	12 PCS
7		PLASTIC CORNER CLIP		6 PCS

*ABOVE HARDWARE ARE PACKED IN #B2048-BC4S FOR ASSEMBLY
LES ÉLÉMENTS DE QUINCAILLERIE CI-DESSUS SONT EMBALLÉS DANS LE RÉFÉRENCE #B2048-BC4S POUR L'ASSEMBLAGE

** Screwdriver/ tournevis (not provided) 



DO NOT TIGHTEN BOLTS UNTIL COMPLETELY ASSEMBLED/
NE PAS SERRER LES BOULONS JUSQU'À CE QUE LE MONTAGE SOIT COMPLÈTMENT TERMINÉ.

MADE IN MALAYSIA / FABRIQUÉ AU MALAISIE

PAGE 1 OF 5 / PADE 1 SUR 5

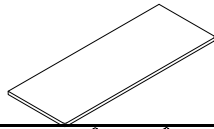
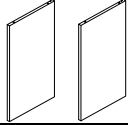

ASSEMBLY INSTRUCTION/ INSTRUCTION D'ASSEMBLAGE

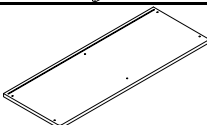
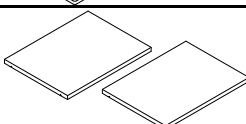
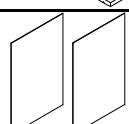
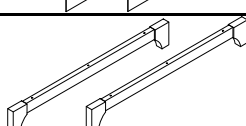
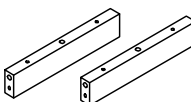
B2048-BC4S PART LIST / LISTE DE PIÈCES			
NO.	DESCRIPTION / LA DESCRIPTION	SKETCH / EQUISSER	QTY / QTÉ
A	TOP PANEL / PANNEAU SUPÉRIEUR		1 PC
B	SIDE PANEL (LEFT & RIGHT) / PANNEAU LATÉRAL (GAUCHE ET DROITE)		2 PCS
C	CENTER PANEL / PANNEAU CENTRAL		1 PC
D	BOTTOM PANEL / PANNEAU INFÉRIEUR		1 PC
E	SHELF PANEL / PANNEAU D'ÉTAGÈRE		2 PCS
F	BACK PANEL / PANNEAU ARRIÈRE		2 PCS
G	LEG FRAME / PIED DU CADRE		2 PCS
H	SIDE CROSS BAR / BARRE TRANSVERSALE		2 PCS

DO NOT TIGHTEN BOLTS UNTIL COMPLETELY ASSEMBLED/
NE PAS SERRER LES BOULONS JUSQU'À CE QUE LE MONTAGE SOIT COMPLÈTMENT TERMINÉ.

MADE IN MALAYSIA / FABRIQUÉ AU MALAISIE

PAGE 2 OF 5 / PADE 2 SUR 5

STEP 1 / ÉTAPE 1

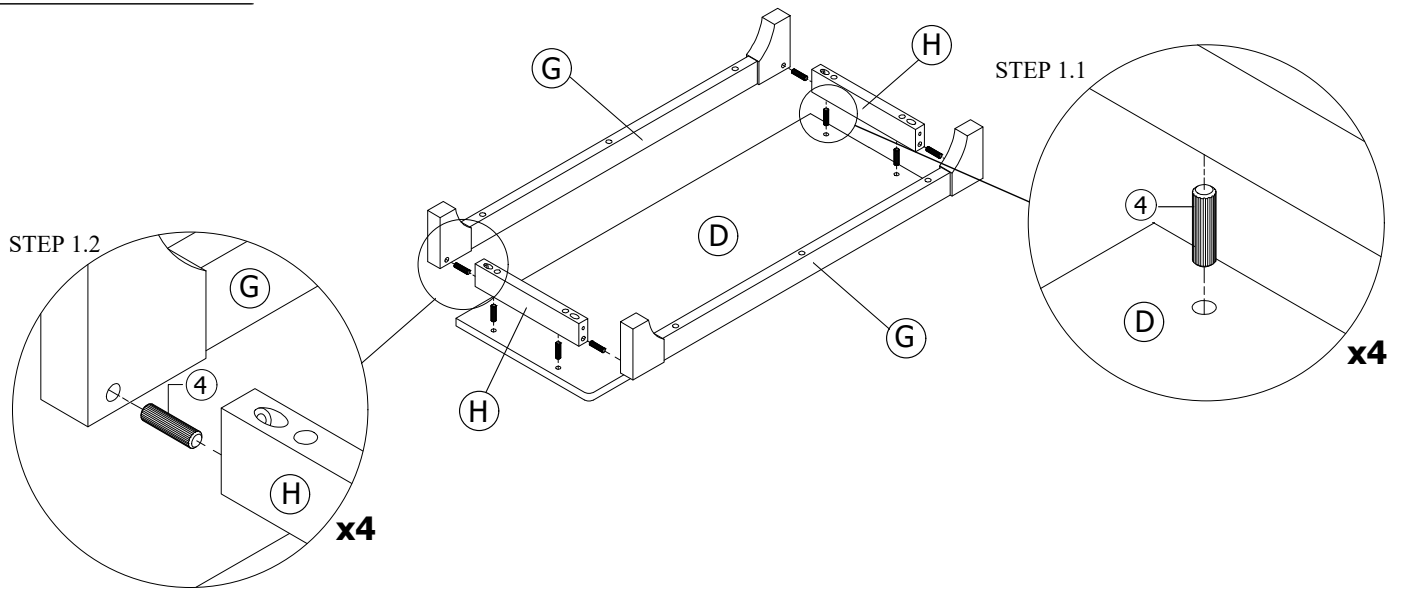

STEP 2 / ÉTAPE 2

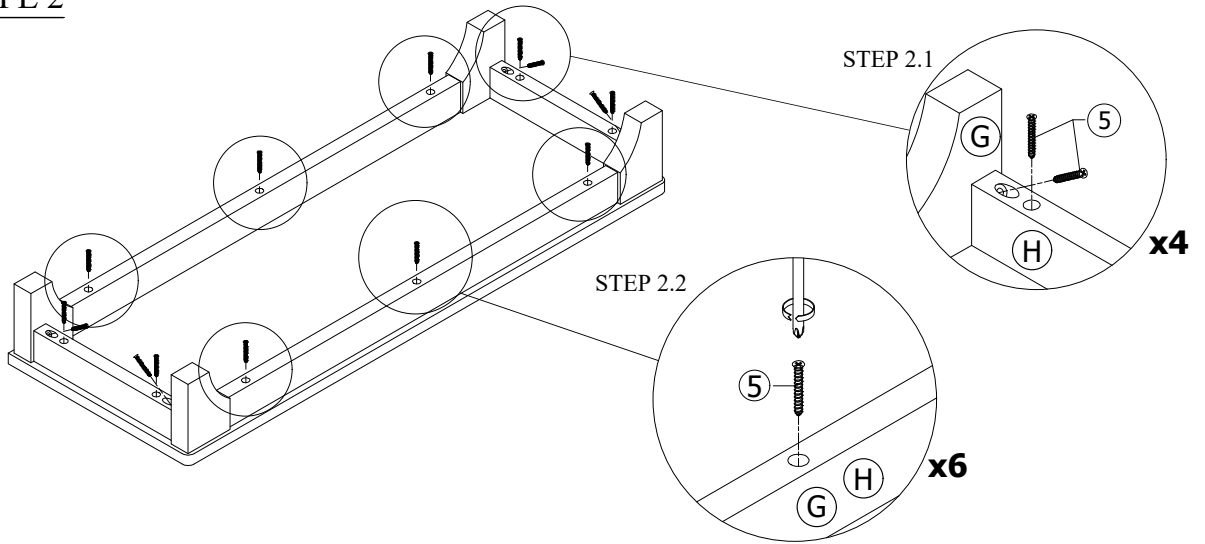

STEP 3 / ÉTAPE 3

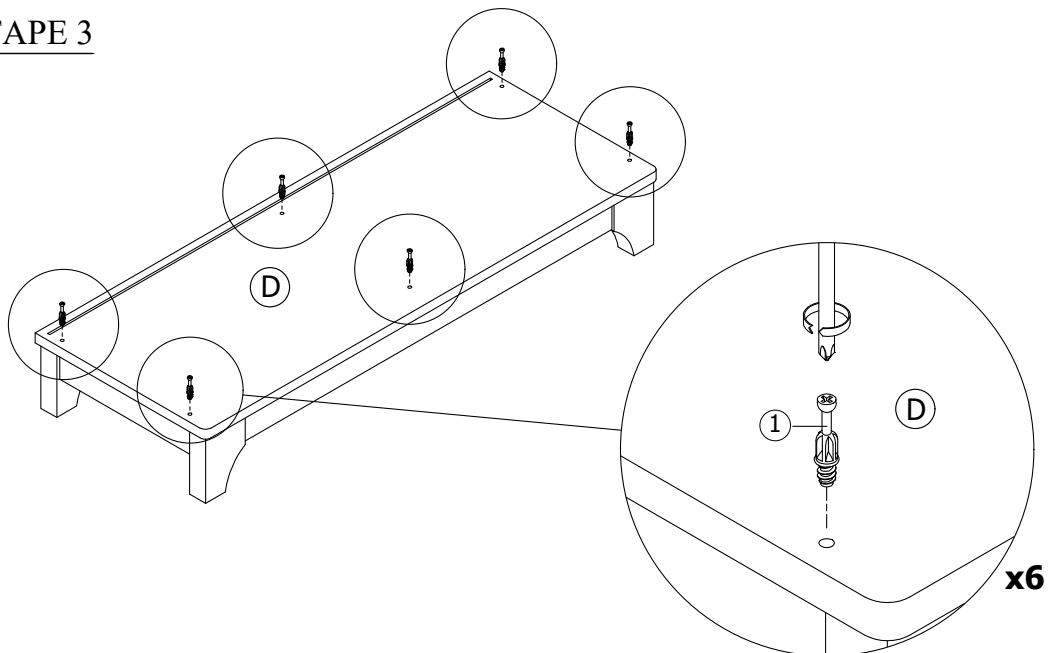

STEP 4 / ÉTAPE 4

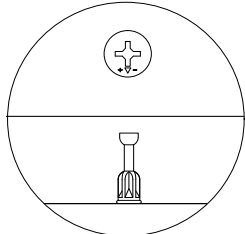
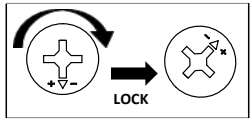

(Zoom In View)

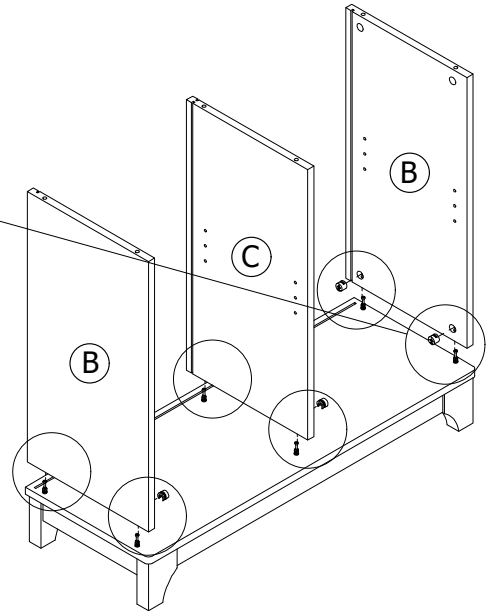
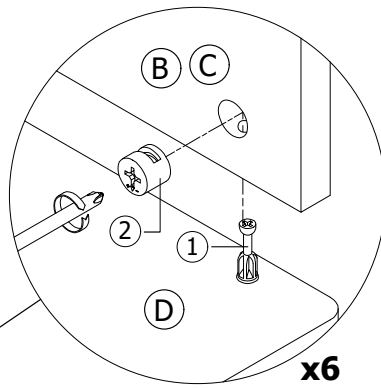

STEP 5 / ÉTAPE 5

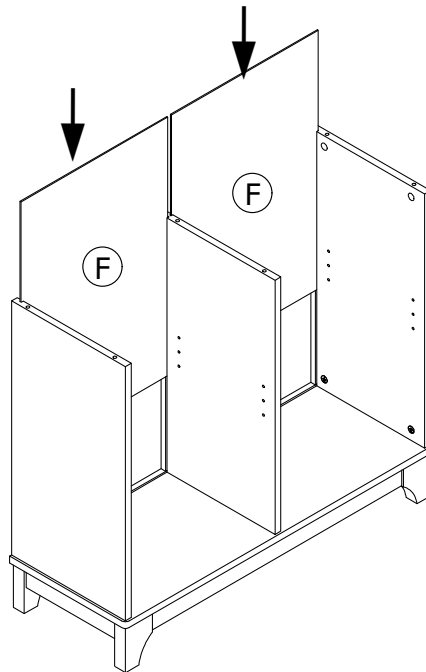

NOTE:
Slot *Back Panel (F)* proper way on groove line.

STEP 6 / ÉTAPE 6

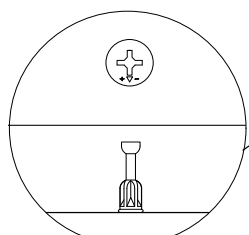
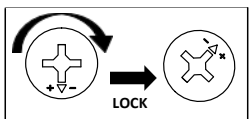

(Zoom In View)

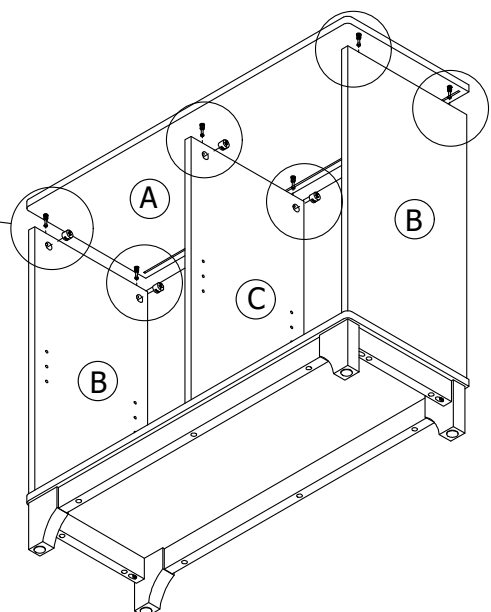
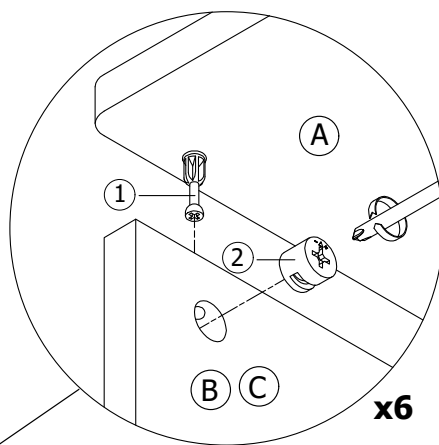

STEP 7 / ÉTAPE 7

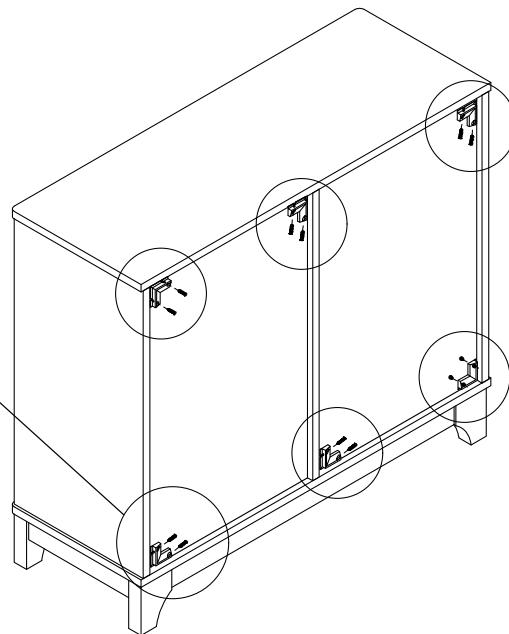
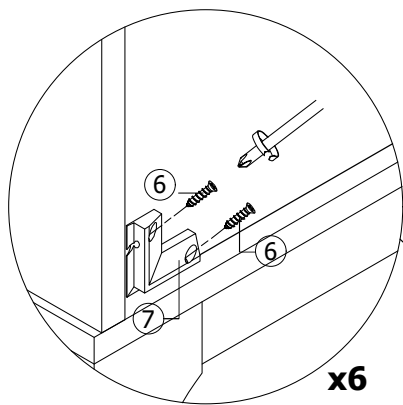

NOTE:

Ensure all *plastic corner clip* (7) are securely fastened at each corner of the *Back Panel* (F).

STEP 8 / ÉTAPE 8

STEP 8.1

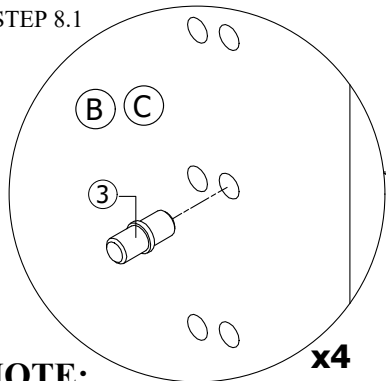

NOTE:

Install *shelf pin* (3) into **RIGHT** locating holes as shown.

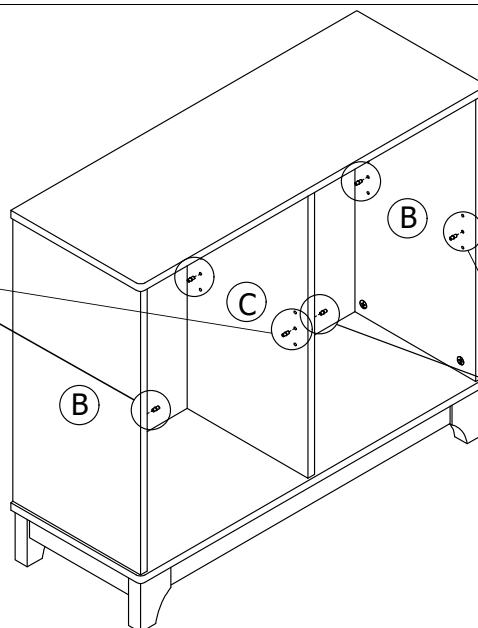

NOTE:

Install *shelf pin* (3) into **LEFT** locating holes as shown.

STEP 8.2

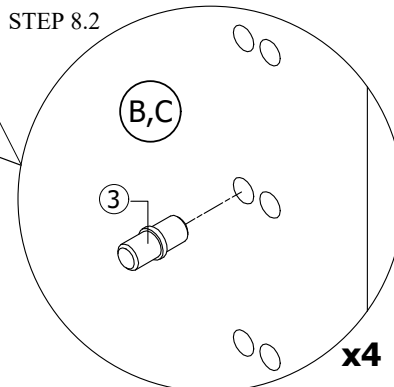

STEP 9 / ÉTAPE 9

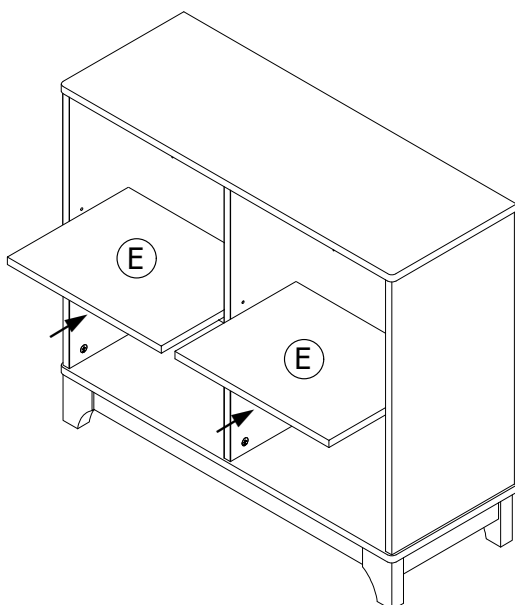

COMPLETED / COMPLÉTÉ

